

## Product data

### Features

- Highly miniaturized encoder
- Differential inductive sensing principle
- Insensitive to magnetic interference fields
- Robust against oil, water, dust, particles
- Ultra-thin encoder and codewheel (total < 2 mm)
- Optional with cable, connector and holder

### Applications

- Brushed and brushless motors
- Industrial / laboratory / office automation
- Rotary stages
- Robotics, assembly equipment

### Key Specifications

Output format.....A and B in quadrature + Index  
 Resolution.....256 – 1'474'560 CPR  
 Maximum speed .....up to 8'600 RPM  
 Airgap .....up to 0.6 mm  
 Supply.....5 V, 30 mA  
 Temperature .....-40 to 125°C  
 Codewheels.....diameter 28, 53 or 73 mm

### Description

The IT3403C incremental encoder kit consists of an encoder and a codewheel (Fig. 1). The encoder consists of two integrated circuits in a PCB housing. It provides incremental A and B output signals in quadrature and an Index signal, which is synchronous to A and B (Fig. 2). The codewheel is a PCB with passive copper strips.

### Resolution, maximum speed and airgap

The resolution and the maximum speed of the encoder are user-programmable or can be programmed ex-factory. The resolution depends on a filter setting that limits the maximum speed of the encoder vs. the codewheel. The resolution also depends on the maximum distance between the encoder and the codewheel. Tables 2 and 3 allow the configuration of resolution and maximum speed for a certain maximum air-gap.

### Codewheel

The codewheel is shown in Fig. 4 and is selected in Table 5. The codewheel may be mounted on a hub, using a rim for accurate positioning in front of the encoder.

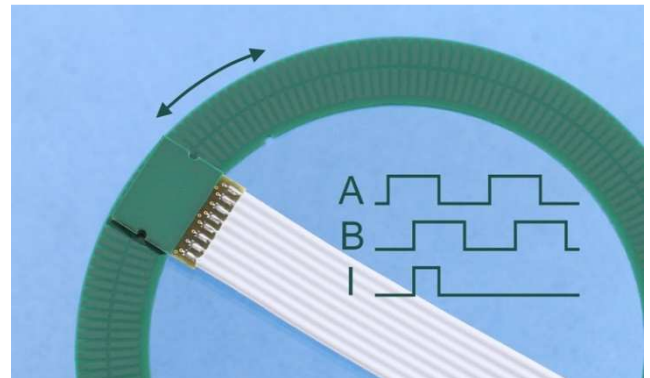
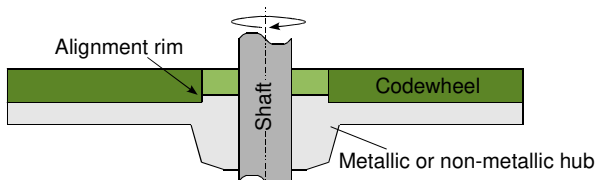

### Encoder holders

Different encoder holder options are available and can be selected in Table 6.

The encoder holder **type A** (Fig. 5) may be mounted on any substrate using 4 screw-holes. It has a strain relief for the cable.

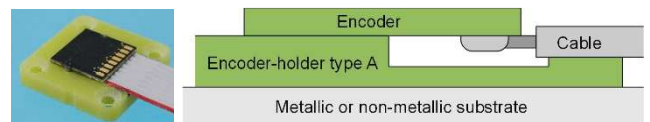

The encoder holder **type B** (Fig. 3) may be mounted on any substrate. Use half-holes on encoder PCB housing and alignment pins for accurate positioning.

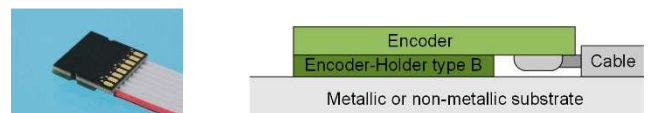

The encoder without holder may be mounted on non-metallic substrates. Use half-holes on encoder housing and alignment pins for accurate positioning.

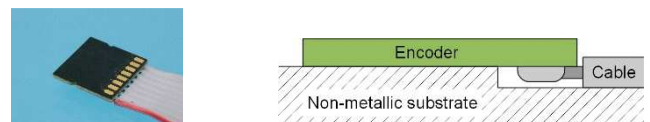

### Encoder cable and connector

The encoder is supplied with a flat cable of pitch 1.27 mm and a connector (Fig. 6). The cable type and length and the connector type are selected in Tables 7 and 8.

### 3D models of encoder, holders and codewheels

STEP and IGES 3D models available on [www.posic.com](http://www.posic.com).

## Specifications

### Recommended Operating Conditions

Parameter	Symbol	Remark	Min	Typ	Max	Unit
Supply voltage	VDD		4.5	5.0	5.5	V
Operating Temperature	T <sub>A</sub>		-40		125	°C
Airgap	Z			0.2		mm
Radial play + eccentricity	ΔY				0.1	mm
Axial play	ΔZ				0.1	mm

### Electrical Characteristics

Electrical characteristics over recommended operating conditions, typical values at VDD = 5.0 V, T<sub>A</sub> = 25°C.

Parameter	Symbol	Remark	Min	Typ	Max	Unit
Supply current	IDD	No load	15	30	45	mA
Operating frequency	F	A/B signals, CC = 04 – 10 A/B signals, CC = 11 – 15			1000 100	kHz
Derating for F <sub>A/B</sub> and for Max speed (Table 2)		Temp range 0 to 65°C Temp range -20 to 100°C Temp range -40 to 125°C			-8 -14 -20	%
High level output voltage	V <sub>OH</sub>	I <sub>L</sub> = 2 mA	VDD-0.5			V
Low level output voltage	V <sub>OL</sub>	I <sub>L</sub> = 2 mA			0.5	V
Rise time, fall time	t <sub>r</sub> , t <sub>f</sub>	C <sub>L</sub> = 47 pF			20	ns

### Encoding Characteristics

Encoding characteristics over recommended operating conditions, typical values at VDD = 5.0 V, T<sub>A</sub> = 25°C, airgap = 0.2 mm, speed = 10 RPM.

Parameter	Symbol	Remark	Min	Typ	Max	Unit
Pulse width error	ΔP	Nominal value 180°e		10	50	°e
State width error	ΔS	Nominal value 90°e		10	60	°e
Phase shift error	ΔΦ	Nominal value 90°e		10	45	°e

### Linearity

For high-resolution high-precision applications, it is possible to linearize the encoder by means of a Look-Up Table (LUT) that is located inside the encoder. The LUT can be programmed in volatile or in non-volatile memory by means of the Evaluation and Programming Tool (EPT) or it can be pre-programmed ex-factory. The LUT option is selected in Table 4.

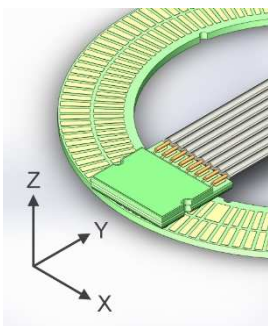

Fig. 1 Coordinate system XYZ.

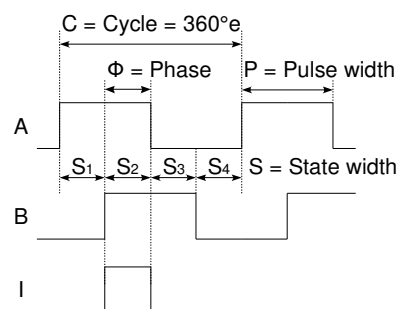

Fig. 2 Encoder output signals A and B in quadrature and Index.

### Definitions

Airgap	Distance between encoder and codewheel in Z-direction. See Fig. 1.
Cycle	One A quad B period, see Fig. 2.
CPP	Cycles per codewheel-period.
°e	Electrical degree (one Cycle is 360°e)
Phase shift Φ	Number of electrical degrees between the center of the high state of channel A and the center of high state of channel B. Nominal 90°e. Fig. 2.
Pulse width P	Number of electrical degrees that an output is high during one cycle. Nominal 180°e. Fig. 2.
State width S	Number of electrical degrees between two neighboring A and B transitions. Nominal value is 90°e. See Fig. 2.

## Technical drawings

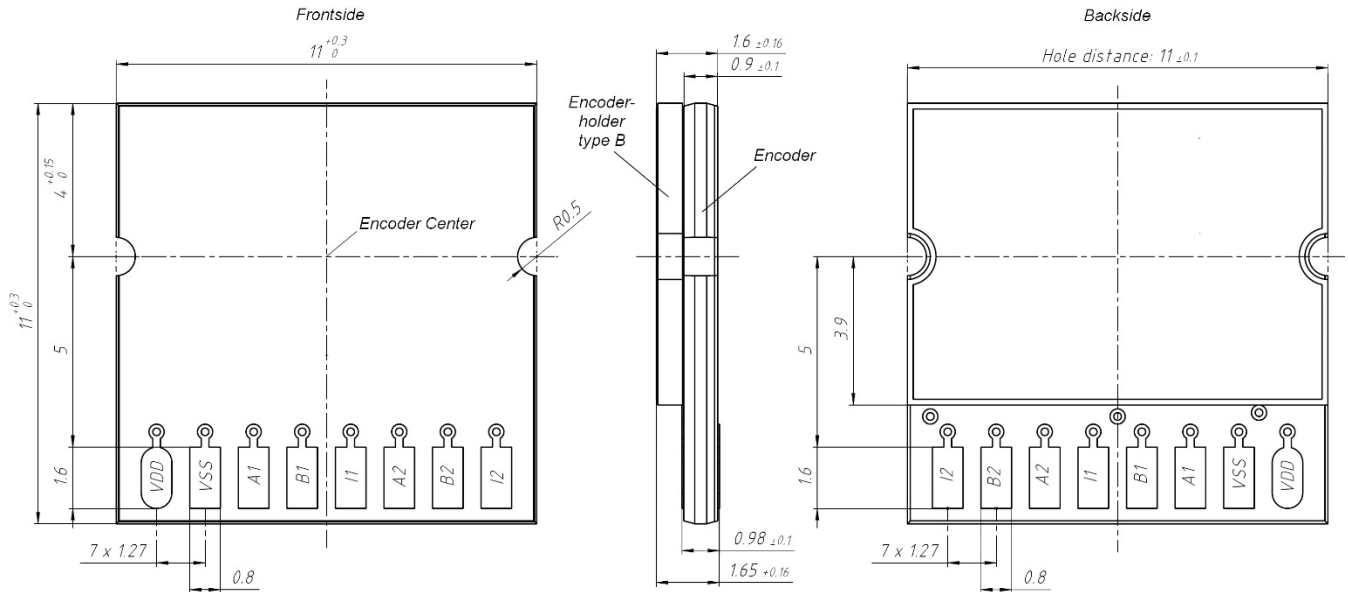
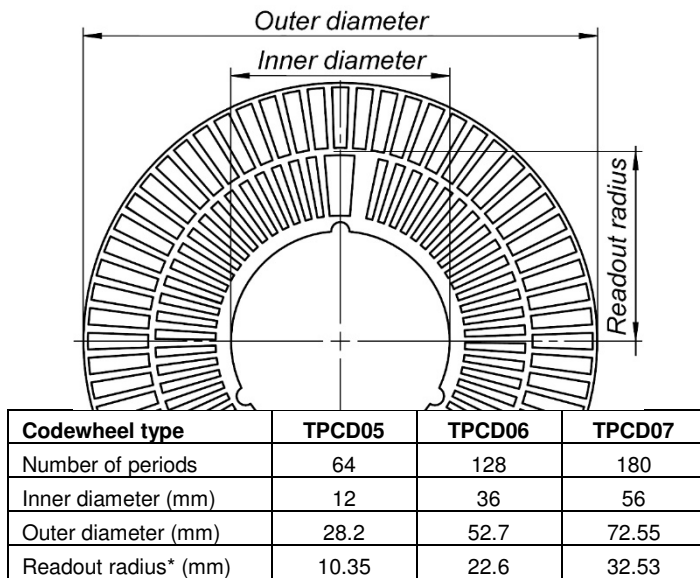

Fig. 3 Dimensions of IT3403 encoder on encoder-holder type B. The “Encoder center” must be centered with respect to the “Readout radius” of the Codewheel (Fig 4)



\* Readout Radius = position of Encoder Center (Fig. 3)  
Codewheel thickness 0.73 mm +/- 10%

Fig. 4 Codewheel dimensions.

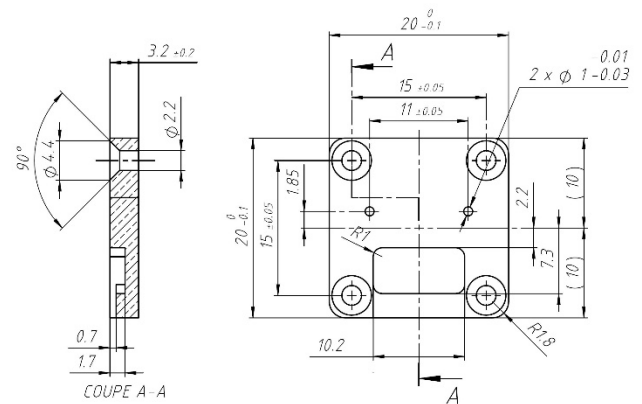

Fig. 5 Encoder Holder type A (see Table 6).

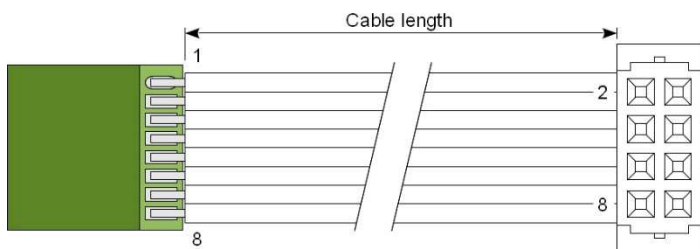

Fig. 6 Encoder with flat cable (pitch 1.27 mm) and 8-pin DIN41651 connector.

Connector pin	Name	Description
1	VDD	5V Supply
2	VSS	Ground
3	A1	Output A
4	B1	Output B
5	I1	Output Index
6	A2	For programming purposes
7	B2	
8	I2	

**Ordering information**

Ordering code: IT3403C-ABBCCD-EEEEEE-F-GGG-HH

A	Orientation	Table 1
BB	Maximum speed	Table 2
CC	Resolution	Table 3
D	Look-Up Table	Table 4
EEEEEE	Codewheel	Table 5
F	Encoder holder	Table 6
GGG	Cable	Table 7
HH	Connector	Table 8

Table 1: Orientation. Arrows indicate direction of movement of codewheel with rising edge A prior to B.

A	Orientation
0	Not progr.
3	0°

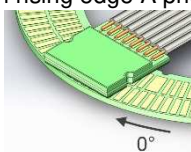

Table 2: Maximum speed

BB	Max speed (RPM)*			Max value CC
	Nr. of periods on Codewheel			
	64	128	180	
00	Not programmed			
01	4	2	1	15
02	8	4	2	15
03	16	8	5	14
04	33	16	11	13
05	67	33	23	12
06	134	67	47	11
07	269	134	95	10
08	539	269	191	10
20	4'313	2'156	1'533	10
21	8'626	4'313	3'067	9

\*Max speed valid at 25°C, temp. derating in specs, page 2. Lower Max speed leads to a lower jitter of the A/B outputs.

Table 3: Resolution

CC	Resolution CPR			Max value BB	Max Airgap* (mm)
	Nr. of periods on Codewheel				
	64	128	180		
00	Not programmed				
04	256	512	720	21	0.6
05	512	1'024	1'440	21	0.6
06	1'024	2'048	2'880	21	0.5
07	2'048	4'096	5'760	21	0.5
08	4'096	8'192	11'520	21	0.4
09	8'192	16'384	23'040	21	0.4
10	16'384	32'768	46'080	20	0.3

© Copyright 2019 POSIC. All rights reserved. No part of this document may be reproduced without the prior written consent of POSIC. Products and companies mentioned in this document may be trademarks or registered trademarks of their respective owners. Information in this document is believed to be accurate and reliable and may be changed without notice. No responsibility is assumed by POSIC for its use, nor for infringements of patents or other rights of third parties which may result from its use. Some commercial or geographical restrictions may apply to the sale of this product. No license is granted by implication or otherwise under any patent or patent rights of POSIC. In no event shall POSIC, its employees, its contractors, or the authors of this document be liable for special, direct, indirect, or consequential damage, losses, costs, charges, claims, demands, claim for lost profits, fees, or expenses of any nature or kind. POSIC products are not designed, intended, authorized or warranted to be suitable for use in life-support applications, devices or systems or other critical care applications. Inclusion of POSIC products in such applications is understood to be undertaken solely at the customer's own risk. Should a customer purchase or use POSIC products for any such unauthorized application, the customer shall indemnify and hold POSIC and its officers, employees, subsidiaries, affiliates, representatives and distributors harmless against all claims, costs, damages and attorney fees which could arise.

11	32'768	65'536	92'160	06	0.3
12	65'536	131'072	184'320	05	0.2
13	131'072	262'144	368'640	04	0.2
14	262'144	524'288	737'280	03	0.2
15	524'288	1'048'576	1'474'560	02	0.2

\* Recommended airgap = 0.2 mm. Sequence of A and B transitions is correct up to Max Airgap, but encoding specifications may be out of range.

Table 4: Look-Up Table (LUT)

D	Look-Up Table programmed in OTP
0	Not programmed
1	LUT according to codewheel, to be specified
8	Custom LUT, to be specified
9	Default LUT, no codewheel specified

Table 5: Codewheel (see Fig. 4)

EEEEEE	Codewheel	Description
00000	No codewheel	
05064	TPCD05	64 periods, OD 28.2 mm
06128	TPCD06	128 periods, OD 52.7 mm
07180	TPCD07	180 periods, OD 72.6 mm

Table 6: Encoder holder

F	Encoder holder
0	No holder
A	Holder A (Fig. 5)
B	Holder B (Fig. 3)

Table 7: Cable

GGG	Cable
000	No cable
0xx	Flat ribbon cable, -20 to 100°C, length xx cm
1xx	Flat ribbon cable, -40 to 125°C, length xx cm

Table 8: Connector

HH	Connector*
00	No connector
04	8-pin connector DIN 41651 (Fig. 6)
05	10-pin connector DIN 41651

\* Connector temperature range -20 to +100°C